

FAMILY OWNED AND OPERATED SINCE 1933

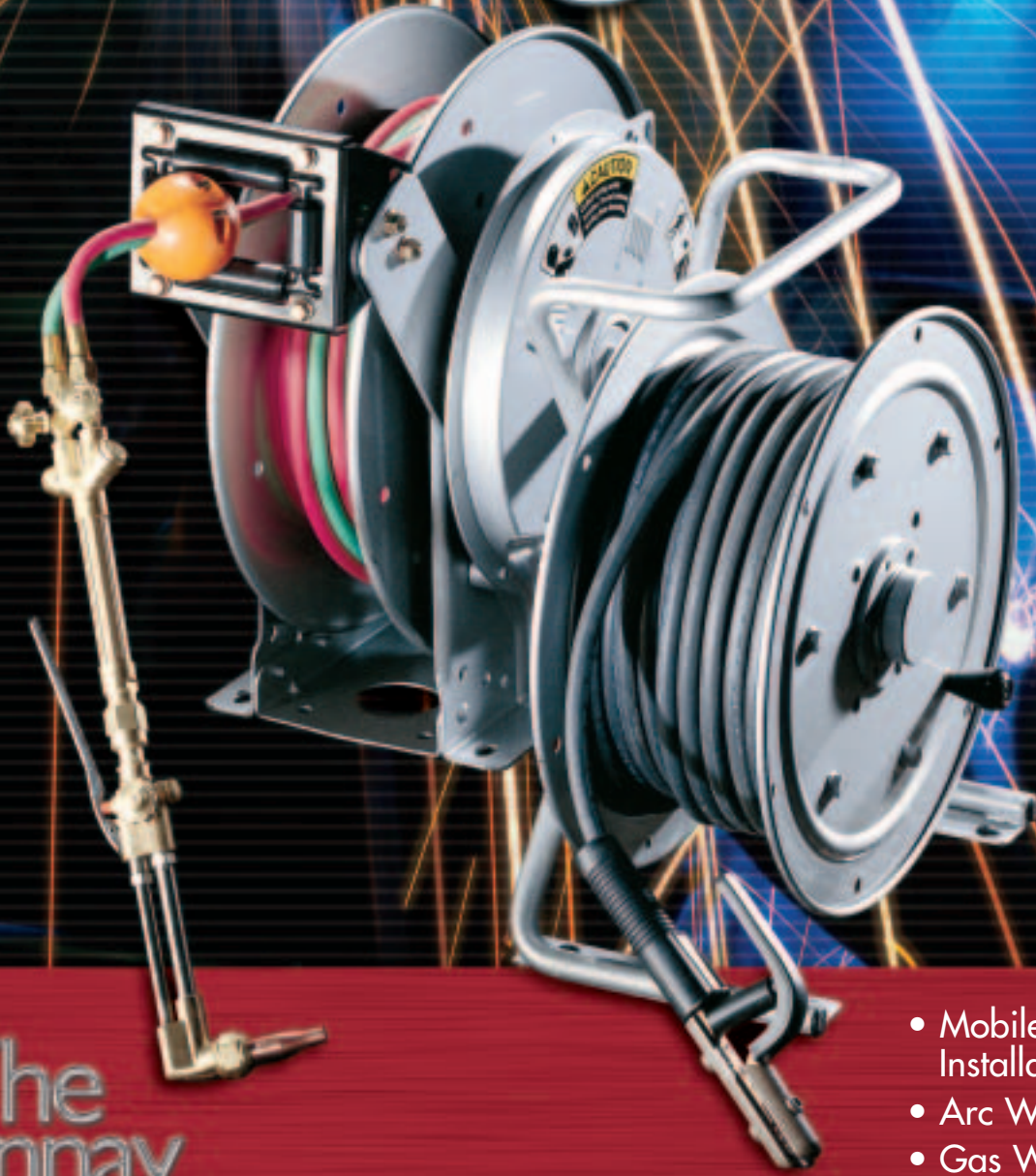

Hannay Reels
The reel leader.

Welding Reels



The
Hannay
Way

- Mobile and Fixed Installations
- Arc Welding
- Gas Welding
- Cutting Operations

www.hannay.com

Pride in workmanship • Reels built to order • Consistent quality • Service with integrity • Value for your dollar

SWCR/WCR

ARC WELDING REELS POWER OR MANUAL REWIND

To handle #2 through 4/0 cable to 400 amps.

- 400 amp rated rotary electrical device.
- Instant use with any cable length unwound.
- For use with single conductor electrode cable or grounding lead.
- Quick connection to your welder.
- 4-way roller assembly. Roller position must be specified.

WCR

- Gear driven crank rewind, chain & sprocket powered by an electric, hydraulic or compressed air motor or spring rewind.
- Auxiliary rewind and Pinion brake standard.

SWCR

- Non sparking ratchet assembly.
- Declutching arbor is provided to prevent damage from reverse winding.
- A cable stop should be used.



Series SWCR

Standard Configuration Shown

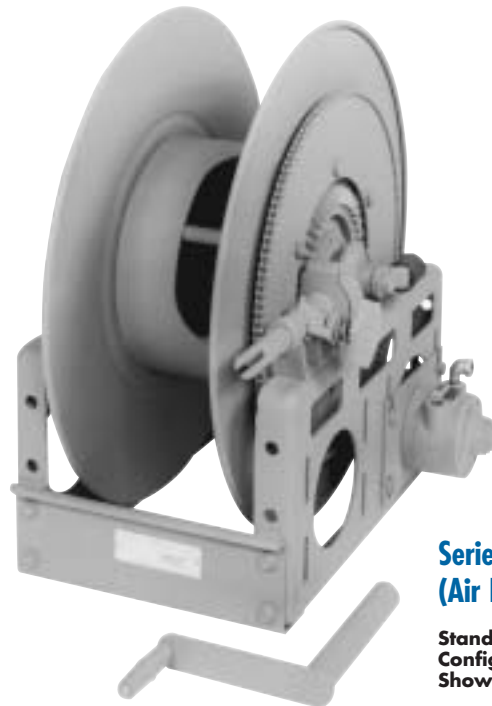

**Series WCR
(Air Power AWCR)**

Standard Configuration Shown



**Protective Ground Lug Boot
part no. 9955.0202**

SWCR/WCR

SWCR Parts Drawing – ISO 94, and WCR Parts Drawing – ISO 188

Model Number	Cable Capacity of Reel feet m.						Approx. Weight Crank/Spring Rewind ³ lb. kg.		Standard Roller Assy	Reel Dimensions*** inches mm.											
	Gauge of Cable						NET	SHIP		A	B	D	E	F CRANK	F PWR.	F SPRING	G	H	X	Y	
	#2	#1	1/0	2/0	3/0	4/0															
For Power Rewind See Note 4	O.D. (in)	.50	.58	.62	.67	.72	.81														
	O.D. (mm)	13	15	16	17	18	21														
SWCR716-23-24-15.5G		85	85	60	60	60	40	85	120	R204	9.25	3	23.25	24.38	-	-	11	23.88	12.5	4.5	20.25
		26	26	18	18	18	12	39	54		235	76	591	619	-	-	279	607	318	114	514
SWCR716-25-26-15.5B		-	-	-	-	60	50	91	126	R204	9.25	3	25	26.12	-	-	11	25.88	13.5	4.5	22
		-	-	-	-	18	15	41	57		235	76	635	663	-	-	279	657	343	114	559
SWCR716-25-26-15.5A		-	-	100	-	-	-	106	141	R205	10.25	3	25	26.12	-	-	12	25.88	13.5	5.5	22
		-	-	30	-	-	-	48	64		260	76	635	663	-	-	305	657	343	140	559
WCR16-19-21		-	275	200	200	150	150	71	106	-	13	7.5	20.5	21.88	15	19.75	-	21.5	12.12	7.75	16.75
		-	84	61	61	46	46	32	48		330	191	521	556	381	502	-	546	308	197	425
WCR16-23-24		-	-	-	-	300	200	78	113	-	13	7.5	20.5	23	15	19.75	-	23.5	12.12	7.75	16.75
		-	-	-	-	91	61	35	51		330	191	521	584	381	502	-	597	308	197	425

Notes:

- Specifications subject to change.
- Upon request, reels can be supplied with drum lengths other than shown and with disc sizes in other diameters.
- Weights shown in chart are for crank or spring rewind models. ADD these amounts for power rewind models: (Series WCR)

	Net (lbs.)	Ship (lbs.)	Net (kg.)	Ship (kg.)
Electric	40	40	15.1	15.1
Hydraulic	20	20	9.1	9.1
Air	20	20	9.1	9.1
- When ordering power rewind Series WCR, prefix model number with:
 A = Air Rewind EP = Electric Rewind HD = Hydraulic Rewind
 (Air rewind reels are supplied with control valve and hose; 12v and 24v DC rewind reels are supplied with switch and solenoid; 115v AC rewind reels are not supplied with switch but can be ordered separately; hydraulic rewind reels are not supplied with control valve.)

5. Be sure to check dimensions and weights prior to ordering.

6. For welding hose and cable specifications see page 9.

***x,y indicate mounting holes.

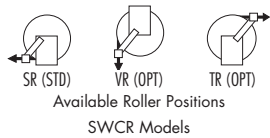
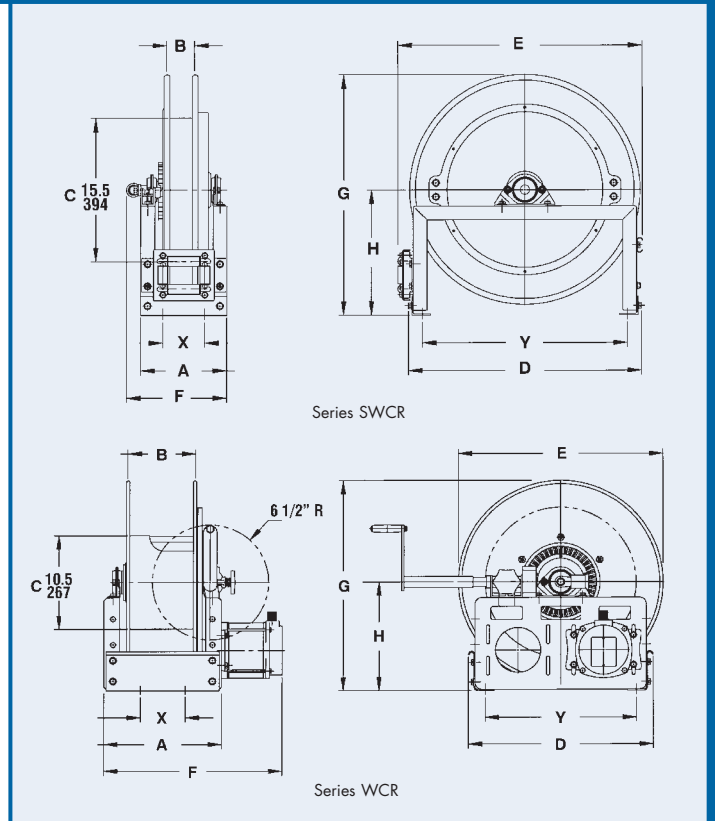

TWCR

DUAL ARC WELDING REEL MANUAL REWIND

To handle #1 through 4/0 cable to 400 amps.

- Designed to handle grounding and arc welding leads on the same reel unit.
- Two independent spools to hold separate lengths of welding cable.
- 400 amp rotary electrical device for instant and constant use.
- Long-wearing Delrin bearings provide electrical insulation and lube-free ease of operation.
- Gear driven crank rewind with a removable handle.
- Pinion brake is standard.



Standard Configuration Shown



Protective Ground Lug Boot
part no. 9955.0202

Parts Drawing – ISO 185

Model Number	Cable Capacity of Reel feet m.					Approx. Weight Crank Rewind lb. kg.		Reel Dimensions*** inches mm.										
	Gauge of Cable					NET	SHIP	A	B	C	D	E	F	G	H	X	Y	
	#1	1/0	2/0	3/0	4/0													
	O.D. (in)	.58	.62	.67	.72	.81												
	O.D. (mm)	15	16	17	18	21												
TWCR12-17-18		–	50	50	45	40	78	113	16.5	4	10.5	18	20.75	21	18.12	9.88	9	14.25
		–	15	15	14	12	35	51	419	102	267	457	527	533	460	251	229	362
TWCR14-17-18		125	100	100	80	50	80	115	20.5	6	10.5	18	20.75	25	18.12	9.88	13	14.25
		38	30	30	24	15	36	52	521	152	267	457	527	635	460	251	330	362
TWCR12-19-20		150	100	100	60	60	82	117	16.5	4	10.5	18.5	21	21	19.75	10.38	9	14.75
		46	30	30	18	18	37	53	419	102	267	470	533	533	502	264	229	375
TWCR14-19-20		–	150	150	100	80	84	119	20.5	6	10.5	18.5	21	25	19.75	10.38	13	14.75
		–	46	46	30	24	38	54	521	152	267	470	533	635	502	264	330	375

Notes:

1. Specifications subject to change.
 2. Be sure to check dimensions and weights prior to ordering.
 3. For welding hose and cable specifications see page 9.
- ***x,y indicate mounting holes.

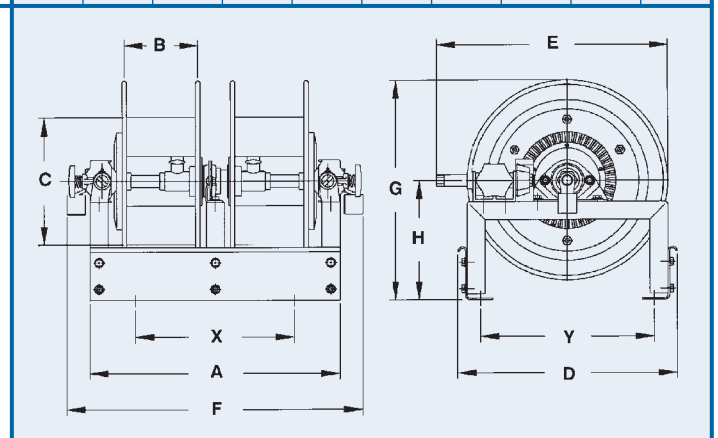

WCR11-17-19



Standard Configuration Shown

PORTABLE REEL MANUAL REWIND

To handle #2 through 4/0 cable to 400 amps.

- Rugged portable reel with carrying handle.
- Long-wearing Delrin bearings.
- For use with single-conductor electrode cable or for grounding lead.
- 400 amp rotary electrical device.
- Manual rewind by a knob permanently attached.
- Adjustable friction brake standard.



Protective Ground Lug Boot
part no. 9955.0202

Parts Drawing – ISO 110

Model Number	Cable Capacity of Reel feet m.						Approx. Weight lb. kg.		Reel Dimensions inches mm.								
	Gauge of Cable						NET	SHIP	A	B	C	D	E	F	G	H	
	#2	#1	1/0	2/0	3/0	4/0											
	O.D. (in)	.50	.58	.62	.67	.72	.81										
	O.D. (mm)	13	15	16	17	18	21										
WCR11-17-19		200	150	100	75	75	50	24*	34	9.25	6	10.5	15.5	16.5	13	18.81	8.69
		61	46	30	23	23	15	11	15	235	152	267	394	419	330	478	221

Notes:

1. Specifications subject to change.
 2. Be sure to check dimensions and weights prior to ordering.
 3. For welding hose and cable specifications see page 9.
- * When shipped as a parcel package (via FedEx or UPS ground).

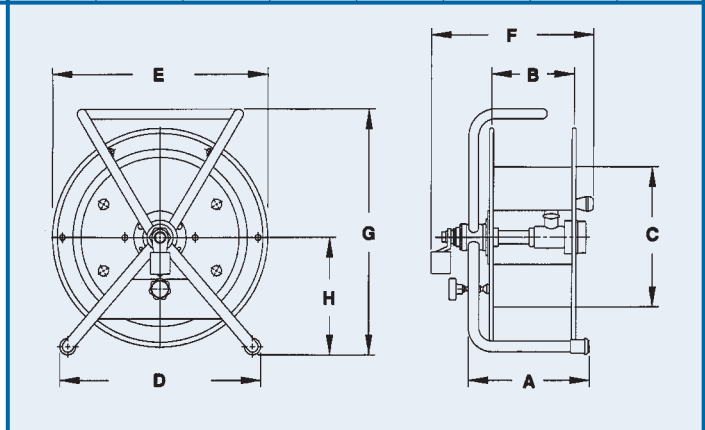

N400

GAS WELDING REELS SPRING REWIND

To handle twin 1/4" through 3/8" welding hose.

- Heavy-duty spring motor.
- Non sparking ratchet assembly.
- Declutching arbor to prevent damage from reverse winding.
- Standard inlets 90° ball bearing swivel joints 1/2" female NPT threads.
- Standard outlets male 9/16"-18 threads right hand for oxygen, left hand for gas.
- Pressures to 300 psi (21 bar).
- Temperatures from -40° F to +200° F (-40° C to +93° C).
- Type of gas used **MUST** be specified.
- 4-way roller assembly. Roller position must be specified.
- Hose stop is required.

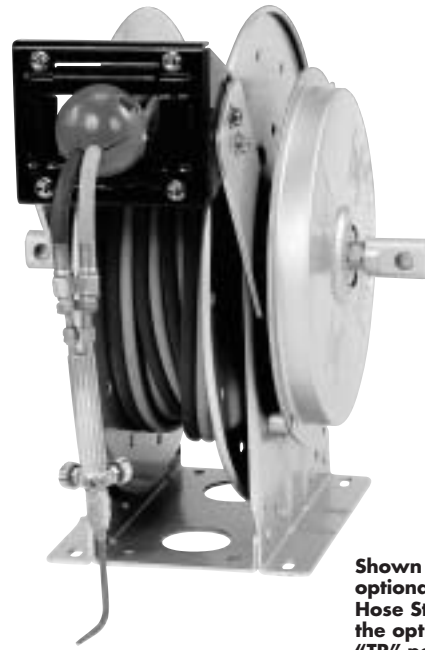

Shown with optional Hose and Hose Stop in the optional "TR" position.

Parts Drawing – ISO 186

Model Number	Hose Capacity of Reel			Approx. Weight		Standard Roller Assy	Reel Dimensions***						
	feet			lb.			inches						
	m.			kg.			mm.						
	I.D. (in)	1/4"	3/8"	NET	SHIP	N/A	B	C	N/E	N/F	N/G	N/H	N/X
	I.D. (mm)	6	9										
N416-19-20-10.5C	2/35	2/35	70*	85	N204	10	4	10.5	20.75	15.12	20	10.62	8
	2/11	2/11	32	39		254	102	267	527	368	508	270	203
N416-19-20-8J	2/50	2/50	74*	90	N204	10	4	8	20.75	15.12	20	10.62	8
	2/15	2/15	34	41		254	102	203	527	368	508	270	203
N416-23-24-10.5G	2/75	2/75	94	109	N204	10	4	10.5	23.75	15.12	24	12.62	8
	2/23	2/23	43	49		254	102	267	603	368	610	320	203
N417-23-24-10.5G	2/100	2/100	95	113	N205	11	5	10.5	23.75	16.12	24	12.62	9
	2/30	2/30	43	51		279	127	267	603	394	610	320	229

Notes:

1. Specifications subject to change.
2. Reel models and capacities shown are for standard drag applications; for vertical lift applications consult factory.
3. Other sizes, from standard components, available on request.
4. **Be sure to check dimensions and weights prior to ordering.**
5. For welding hose and cable specifications see page 9.

NOTICE: A Flexible Connector must be used between the inlet pipe and the inlet swivel joint.

* When shipped as a parcel package (via FedEx or UPS ground).
Net wt. plus carton wt.

***x,y indicate mounting holes.

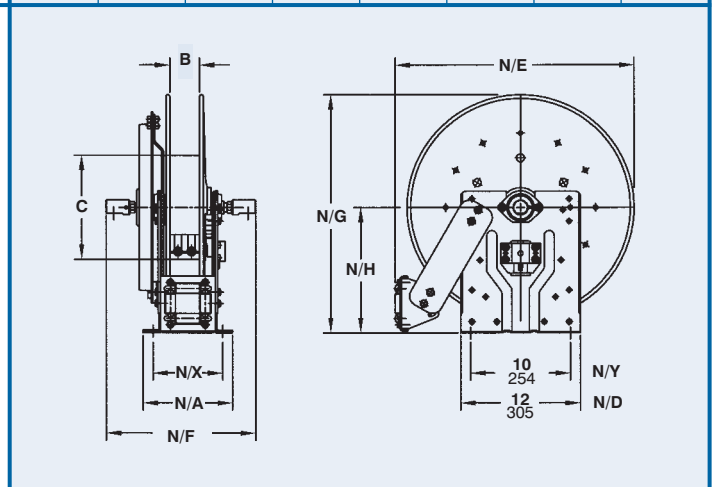
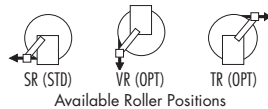

2400

GAS WELDING REELS MANUAL (MX) OR POWER REWIND

To handle twin 1/4" through 3/8" welding hose.

- MX chain drive crank rewind or powered by a compressed air or hydraulic motor.
- MX rewind reels supplied with a Pinion brake.
- Power reels not supplied with a brake.
- Standard inlets 90° ball bearing swivel joints with 1/2" female NPT threads.
- Standard outlets are male 9/16"-18 threads. Right hand for oxygen, left hand for gas.
- Rollers may be purchased. Specify roller position (mounting brackets are necessary).
- Pressures to 300 psi (21 bar).
- Temperatures from -40° F to +200° F (-40° C to +93° C).
- Type of gas used **MUST** be specified.

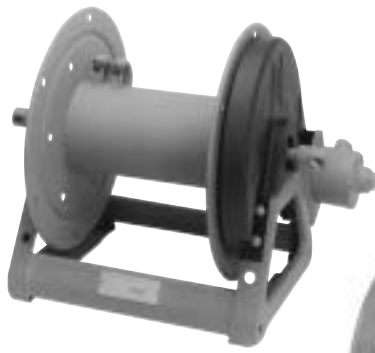

Series 2400
Shown with
Air Rewind



Series 2400
Standard Configuration
Shown with MX Rewind

Power 2400 Parts Drawing – ISO 187
MX Parts Drawing – ISO 213

Model Number	Hose Capacity of Reel			Approx. Weight		Reel Dimensions***						
	feet			NET*	SHIP	inches						
	m.					mm.						
For Power Rewind See Note 5	I.D. (in)	1/4"	3/8"			A	B	E MX	E POWER	F MX	F POWER	X
	I.D. (mm)	6	9									
	O.D. (in)	.53"	.66									
	O.D. (mm)	13	17									
MX2414-17-18	2/100	2/75	2/75	31	52	11	6	18.5	19	28.5	18.75	9.5
	2/30	2/23	2/23	14	24	279	152	470	483	724	476	241
MX2416-17-18	2/150	2/100	2/100	32	53	13	8	18.5	19	30.5	20.75	11.5
	2/46	2/30	2/30	15	24	330	203	470	483	775	527	292
MX2420-17-18	-	2/150	2/150	34	55	17	12	18.5	19	34.5	24.75	15.5
	-	2/46	2/46	15	25	432	305	470	483	876	629	394
MX2426-17-18	-	2/200	2/200	36	59	23	18	18.5	19	40.5	30.75	21.5
	-	2/61	2/61	16	27	584	457	470	483	1029	781	546

Notes:

1. Specifications subject to change.
2. Upon request, reels can be supplied with drum lengths other than shown and with disc sizes in other diameters.
3. Weights shown in chart are for crank rewind models. ADD these amounts for power rewind models:

	Net (lbs.)	Ship (lbs.)	Net (kg.)	Ship (kg.)
Hydraulic	15	15	6.8	6.8
Air	15	15	6.8	6.8

4. Dimension "F" is the overall length of standard model reels. On crank rewind models, the dimension shown is with the crank in rewind position. Reels require 2" clearance to remove crank handle.
5. When ordering power rewind models replace MX prefix with:
A = Air Rewind HD = Hydraulic Rewind
(Air rewind reels are supplied with control valve and hose; hydraulic rewind reels are not supplied with control valve.)
6. Be sure to check dimensions and weights prior to ordering.
7. For welding hose and cable specifications see page 9.

NOTICE: A Flexible Connector must be used between the inlet pipe and the inlet swivel joint.

* When shipped as a parcel package (via FedEx or UPS ground).
***x,y indicate mounting holes.

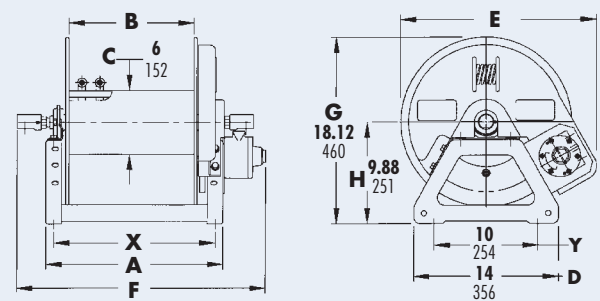

Series 2400 (Power Rewind)

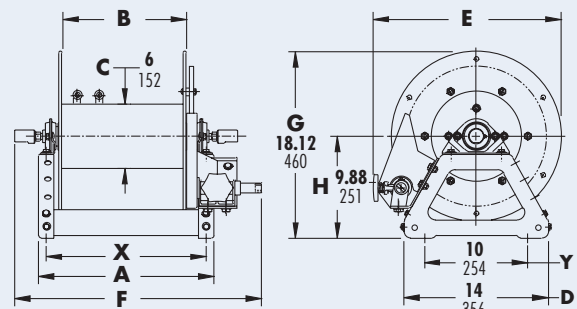

Series MX 2400

G2400

GAS WELDING REELS MANUAL REWIND

To handle twin 1/4" through 3/8" I.D. hose.

- Two swivel joint inlets and two outlet risers to handle two equal lengths of hose.
- Gear-drive crank rewind.
- Pinion brake as standard.
- Standard inlets 90° ball bearing swivel joints 1/2" female NPT threads.
- Standard outlets are male 9/16"-18 threads. Right hand for oxygen, left hand for gas.
- Pressures to 300 psi (21 bar).
- Temperatures from -40° F to +200° F (-40° C to +93° C).
- Type of gas used **MUST** be specified.



Standard Gear Driven Crank Rewind Shown

Parts Drawing – ISO 205

Model Number	Hose Capacity of Reel			Approx. Weight Crank Rewind		Reel Dimensions****			
	feet m.			lb. kg.		inches mm.			
	I.D. (in) I.D. (mm)	1/4" 6	3/8" 10	NET	SHIP	A	B	F	X
	O.D. (in) O.D. (mm)	.53" 14	.66" 17						
G2416-17-18-8		2/150 2/46	2/100 2/30	40 15	50* 23	13 330	8 203	21 533	11.5 292
G2420-17-18-8		– –	2/150 2/46	42 18	50* 23	17 432	12 305	25 635	15.5 394
G2426-17-18-8		– –	2/200 2/61	44 19	50* 23	23 584	18 457	31 787	21.5 546

Notes:

1. Specifications subject to change.
2. Upon request, reels can be supplied with drum lengths other than shown.
3. **Be sure to check dimensions and weights prior to ordering.**
4. For welding hose and cable specifications see page 9.

NOTICE: A Flexible Connector must be used between the inlet pipe and the inlet swivel joint.

- * When shipped as a parcel package (via Fed-Ex or UPS Ground).
- *** x,y indicate mounting holes.

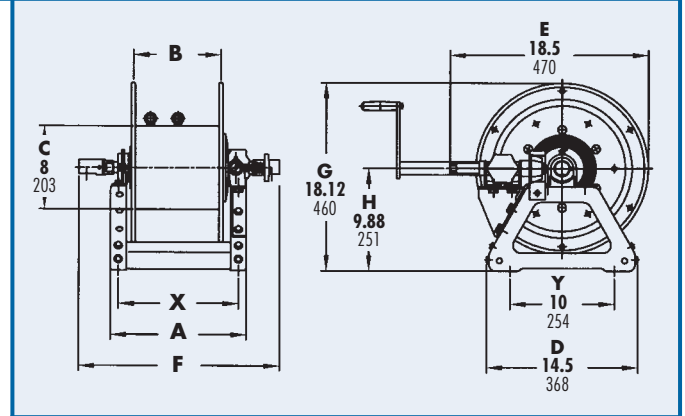

Welding Hose & Cable Specifications.

Welding Hose

Our oxygen/acetylene grade R hose assemblies with inside diameters of 1/4" and 3/8" have working pressures of 200 psi (14 bar), working temperatures of -40° F to +200° F (-40° C to +93° C), and have an EPDM core and cover with one textile braid reinforcement. This hose is designed for oxygen/acetylene only. Grade T oxygen/acetylene, propane, M.A.P.P. hose is also available.

For hose assembly details and pricing, consult your Hannay dealer or factory.

Welding and Grounding Cable

Wire Size (AWG)	Area (Per Conductor)	
	Circ. Mills	Sq. mm
#2	66,500	33.7
#1	84,000	42.6
#1/0	105,600	53.5
#2/0	133,100	67.4
#3/0	167,800	85.0
#4/0	211,600	107.2

For cable pricing consult factory.





Cable Reels

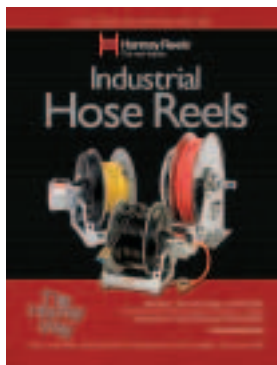

Hose Reels



Ordering & Accessory Guide

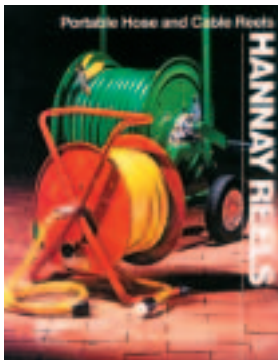

Portable Hose and Cable Reels



Pressure Wash Reels



Stainless Steel Reels



Family owned and operated since 1933, Hannay Reels is a leader in both OEM and aftermarket applications. Hannay offers thousands of standard hose reel and cable reel models, as well as unmatched custom capabilities. We can easily and affordably customize a reel to meet your exact specifications – built to last, delivered fast. Additional catalogs are available through your local Hannay Reels dealer or online at www.hannay.com.



553 State Route 143 • Westerlo, New York 12193-0159
Toll Free Phone: 1-877-GO-REELS • Toll Free Fax: 1-800-REELING

E-mail: info@hannay.com

Intl. Phone: 1-518-797-3791 • Intl. Fax: 1-518-797-3259

www.hannay.com



MADE IN U.S.A.